

I INTRODUCTION

The Varitronics-Inoue IC-2F meter FM transceiver and its 6 meter counterpart, the IC-6F, are the finest commercially produced products for the VHF-FM amateur enthusiast available. No corners have been cut in engineering, design, construction, or performance. The completely solid state character of the units is fully State-of-the-Art. Many new innovations for convenience and superior performance have been incorporated as well. We recommend that you take the time now to carefully read the contents of this manual and become acquainted with this extraordinary transceiver. You may be sure of many, many hours of trouble-free operating pleasure ahead and the pride of ownership that comes from having the best.

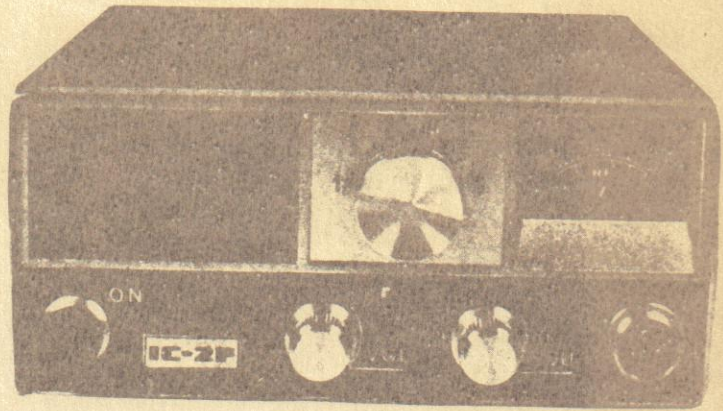

II SPECIFICATIONS

FREQUENCY COVERAGE:

IC-2F, 144 to 148 MHz; IC-6F, 50 to 54 MHz

Note: Maximum frequency spread of 1 MHz recommended between any two receive frequencies or any two transmit frequencies. Six channels available.

SIZE:

2 3/4" high x 6 1/4" wide x 7 1/4" deep.

WEIGHT:

4 3/4 pounds

FRONT PANEL CONTROLS AND JACKS:

Channel switch, on-off switch, volume control, squelch control, microphone jack.

REAR JACKS:

Antenna jack, accessory socket, external speaker jack, fuse holder, power socket.

ANTENNA INPUT:

50 to 52 ohms

POWER REQUIREMENTS:

13.5 VDC \pm 1.5 VDC, negative ground

CURRENT DRAIN:

Receive - 125 mA average; Transmit - 2.5 A

RECEIVER SPECIFICATIONS:

Type:	Double conversion
Sensitivity:	Better than 0.4 μ v @ 20 db of quieting
First IF:	10.7 MHz
Second IF:	455 KHz
Spurious Response:	-60 db
Squelch:	Adjustable -5 to -15 db
Bandwidth:	15 KHz @ 6 db point
Audio Output Power:	1 watt
Output Impedance:	8 ohms
Frequency Control:	Crystal (45 MHz)

TRANSMITTER SPECIFICATIONS:

Power Input:	20 watts
RF Power Output:	10 watts minimum
Frequency Control:	Crystal (18 MHz)
Maximum Frequency Deviation:	Adjustable up to 15 KHz
Audio Input:	10 K

Note: As is our custom, the stated specifications are the minimum performance that may be expected. It is not unusual for owners to experience better performance, i.e., 0.1 μ v receiver sensitivity or 14 watts output from a given unit.



SEMI-CONDUCTOR COMPLIMENT

ASSIGNED #	NOMENCLATURE	FUNCTION
TR1	2SK19	Receiver 1st RF
TR2	CDC5000	Receiver 1st Mixer
TR3	2SC710	Receiver 1st Oscillator
TR4	2SC710	Receiver 2nd Mixer
TR5	2SC710	Receiver 2nd Oscillator
TR6	2SC710	Receiver 1st IF and Buffer
TR7	2SC710	Receiver 2nd IF and Buffer
TR8	2SC710	Receiver Squelch Amplifier
TR9	2SC710	Receiver Squelch Amplifier
TR10	2SC710	Receiver Squelch Regulator
TR11	2SC374	Receiver Audio Driver
TR12	CDC8000	Receiver Audio Regulator
TR13	CDC8000	Receiver Audio Amplifier
TR14	CDC9000	Receiver Audio Amplifier
IC-1	LA-1200	Receiver IF Amplifier
TR15	2SC710	Transmitter 1st Oscillator
TR16	2SC710	Transmitter Buffer
TR17	2SC710	Transmitter Buffer Amplifier
TR18	2SC710	Transmitter Buffer Amplifier
TR19	2SC710	Transmitter 1st Doubler
TR20	2SC773	Transmitter 2nd Doubler
TR21	2SC741	Transmitter 3rd Doubler
TR22	2SC730	Transmitter Buffer Amplifier
TR23	2SC1011	Transmitter Driver
TR24	2SC703	Transmitter PA
TR23(IC-6F)	2SC517	Transmitter Driver
TR24(IC-6F)	2SC517	Transmitter PA
TR25	2SC710	Transmitter First Audio Amplifier
TR26	2SC710	Transmitter Second Audio Amplifier
TR27	2SC710	Transmitter APC Amplifier
TR28	2SC710	Transmitter APC Amplifier
TR29	CDC9000	DC Switching
TR30	CDC8000	DC Switching

III GENERAL DESCRIPTION

The last decade has brought about great interest in the amateur VHF-FM mode. The contributions of many pioneering amateurs to sophisticated Repeater Systems throughout the country can be credited for this interest. Along with this zooming interest has evolved the need for good commercially produced equipment, engineered for the amateur, to meet immediate service. Thus the IC-2F, IC-6F, and their predecessors, the FDFM series, were developed. The IC-2F and -6F transceivers represent the most modern, up-to-date approach to amateur utilization of the FM mode in the VHF spectrum.

The IC-2F and -6F are extremely rugged, completely solid state transceivers. State of the art devices such as Integrated Circuits, Field Effect Transistors, varicap and Zener diodes are engineered into tight knit, straightforward electronic design throughout both transmitter, and receiver. Reliability, low current demand, compactness, unexcelled performance and ease of operation are the net result.

The dual conversion receiver with its FET front end and high-Q filter network boasts low noise and sensitivity of 0.4 uV or less. Signal gain of 90 db or more is accomplished from the second mixer back by virtue of numerous IF amplifier stages incorporated in the dual-in-line flat pack IC and individual transistor amplifiers. The need for additional front end RF amplification is thus eliminated. Zener regulated crystal-controlled first and second local oscillators produce unmatched stability. Audio reproduction is of an unusually high order of distortion-free clarity. Diode protection is used to prevent front end signal overload.

The transmitter section will produce a minimum of 10 watts RF out. Again, a Zener regulated crystal oscillator is employed for initial frequency stability. Six crystal controlled channels are provided for operating convenience and versatility. High-Q LC coupling and shielded stages

provide minimum interstage spurious reaction. An enclosed low pass filter is placed at the output to further insure undesirable frequency products not being emitted. An ingenious final PA transistor protection device, (APC), is incorporated in the final output circuitry. A tiny VSWR bridge and two DC amplifiers constantly monitor the output for high VSWR, a shorted or absent antenna load or other difficulty that would cause irreparable final transistor damage. Should these difficulties occur, the APC instantaneously disables the driver and final PA without damage.

Both transmitter and receiver are housed in sturdy, subdivided, metal chassis which are compactly hinged together and placed one above the other. These in turn are encased between two interlocking metal cabinet halves, providing an extremely durable and rugged unit. Internal RF and DC switching is entirely electronic. No sticking relays to wear or malfunction. Premium care has been taken to filter and regulate internal DC voltages. A DC input filter is provided to eliminate alternator or generator "whine" generated in the vehicle environment. Test points are brought up from all major circuits to facilitate maintenance checks and trouble shooting should the necessity arise. A very handy accessory plug is provided on the rear chassis which permits direct access to the receiver discriminator. Here an outboard "center O" type meter can be used to monitor incoming signal frequency.

Each unit comes complete with built-in speaker, a high-quality dynamic microphone, mobile mounting bracket, microphone clip, DC cabling and plug, external speaker plug, accessory plug, operating manual, and crystals for channels 1 and 2 installed in the case of the IC-2F and channel 1 only in the IC-6F.

A one piece molded satin finish face plate, chrome trim, large S meter, small size and low profile design complete the unit's attractive styling. A welcome addition to any dashboard or ham shack.

IV INSTALLATION INSTRUCTIONS

A. Unpacking:

Carefully remove your transceiver from the packing carton and examine it for signs of shipping damage. When shipped from Varitronics, the transceiver was first unpacked, thoroughly tested and returned to its original carton. This carton was in turn packed in a larger carton and surrounded with at least three inches of packing material for additional cushioning, tightly taped or stapled and committed to a carrier. Should any shipping damage be apparent, notify the delivering carrier or dealer immediately, stating the full extent of the damage. It is recommended you keep the shipping cartons. In the event storage, moving, or reshipment becomes necessary, they come in handy. Accessory hardware, cables, etc., are packed with the transceiver. Make sure you have not overlooked anything.

B. Location:

Where you place the transceiver in your automobile or ham shack is not critical and should be governed by convenience and accessibility entirely. Since the unit is so compact, many mobile possibilities present themselves. The non-smoker, for instance, will find the removal of the auto ashtray will provide a very handy place in most modern cars. In general, the mobile mounting bracket will provide you with some guide as to placement. Any place where it can be mounted with metal screws, bolts, or pop-rivets will work.

In the ham shack, the IC-3P AC power supply is so designed as to be a stand for the transceiver. The mated units occupy a space 6 1/4" x 6 1/4" x 7 1/2". Hardware for accomplishing this is supplied with the IC-3P.

C. Power Requirements:

The IC-2F and -6F are supplied ready to operate from any regulated 13.5 VDC, 2.5 ampere negative ground source. An automobile, 12 volt, negative ground, system is usually more than adequate. Some note must be taken, however, to the condition of the vehicle's electrical system. Items such as low battery, worn generator/alternator, poor voltage regulator, etc., will impair operation of your transceiver as well as the vehicle. High noise generation or low voltage delivery can be traced to these deficiencies. If an AC power supply other than the matching IC-3P is used with your transceiver, make certain it is adequately regulated for both voltage and current. Low voltage while under load will not produce satisfactory results from your transceiver. Receiver gain and transmitter output will be greatly impaired.

CAUTION: EXCESSIVE VOLTAGE (above 15 VDC) WILL CAUSE DAMAGE TO YOUR TRANSCEIVER. BE SURE TO CHECK THE SOURCE VOLTAGE BEFORE PLUGGING IN THE POWER CORD.

Included with your transceiver is a DC power cable with plug attached. The Red Wire is positive (+), the Blue, negative (-). If your mobile installation permits, it is best to connect these directly to the battery terminals. This arrangement eliminates random noise and transient spikes sometimes found springing from automotive accessory wiring. If such an arrangement is not possible, then any convenient B+ lead in the interior of the vehicle and the negative frame can be utilized. Your transceiver provides an internal DC filter that will take out the larger amount of transient difficulties anyway. Remember, the unit operates on a negative ground system only -- it cannot be used in a positive ground automobile. After making your connections, simply insert the plug into your transceiver (see Fig. 1) and tighten snugly with its threaded retaining ring.

When your transceiver is mated with its matching AC power supply, the IC-3P, the power cable from the IC-3P is simply plugged in the same receptacle in the transceiver and the AC line cord into any convenient 115 AC wall receptacle. In this case, the power cable also carries the necessary wiring for the built-in discriminator meter.

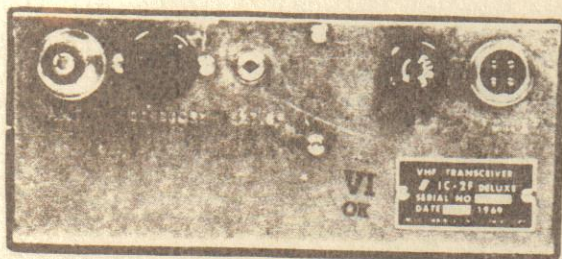

Fig. 1 Rear view of IC-2F/6F

D. Antenna:

The most important single item that will influence the performance of any communication system is the antenna. For that reason, a good, high-quality, gain antenna of 50 ohms impedance is recommended, fixed or mobile. In VHF as well as the low bands, every watt of ERP makes some difference. Therefore, 12 watts average output plus 3 db of gain antenna equals 24 watts ERP, presuming low VSWR of course. The few more dollars investment in a gain type antenna is well worth it.

When adjusting your antenna, whether mobile or fixed, by all means follow the manufacturer's instructions. There are some pitfalls to be aware of. For example, do not attempt to adjust an antenna for lowest VSWR when using a diode VSWR meter not engineered for VHF applications. Such readings will invariably have error of 40% or more. Rather, use an in line watt meter similar to the Drake WV-4 or Bird Model 23 with VHF cartridge. Further, when adjusting a mobile antenna, do so with the motor running, preferably above normal idling speed. This will insure proper voltage level to the transceiver.

Do not become alarmed if your transceiver fails to transmit at times during the antenna tune up procedure. Remember, your transceiver has a built-in Automatic Protection Circuit (APC)* that will disable the transmitter if excessive VSWR, a shorted coaxial line or connector, or other antenna deficiency is present. A quick check on a good 50 ohm dummy load will show the transceiver to be working. The difficulty will lie with the antenna or its transmission line.

The RF coaxial connector (see Fig. 1) on the rear chassis mates with a standard PL-259 connector. Some models may have a metric thread. If this is the case, a matching metric PL-259 is provided. In any event, the RF connector will mate with almost any PL-259 connector if care is taken to seat them properly.

*APC--A tiny VSWR bridge and two DC amplifiers constantly monitor the output for high VSWR, a shorted or absent antenna load or other difficulty that would cause irreparable damage to the final amplifier. Should this occur, the APC instantaneously disables the driver and final PA without damage.

E. Microphone:

A high quality dynamic microphone is supplied with your transceiver. Merely plug it into the proper receptacle on the front panel. Should you wish to use a different microphone, make certain it is of the high impedance type; at least 10 K Ω or better. Particular care should be exercised in wiring also, as the internal electronic switching system is dependant upon it. See the schematic for the proper hook up. Under no circumstances use a "gain pre-amp" type microphone. The audio system in your transceiver is more than adequate and additional pre-amplification unnecessary. To use this class of microphone is to invite distortion and possible damage to the transceiver.

F. Channels:

Your transceiver has six channels, both transmit and receive, or a total of 12 crystal positions. The channel selector switch selects one transmit and one receive channel in each of its six positions. The IC-2F is supplied with crystals for two channels. The usual set up is as follows. Channel 1 transmits on 146.34 MHz and receives on 146.94 MHz. Channel 2 transmits on 146.94 MHz and also receives on 146.94 MHz (simplex). In order to accomplish this, only one receive crystal is used and the first and second crystal positions are jumpered together at the crystal switch. This eliminates the necessity of two crystals for one job and simplifies the one frequency "tweaking." However, if you wish to change the receiving frequency for channel 1 or 2, the jumper will have to be removed. It is a short piece of wire soldered between the two switch terminals on the rear of the channel selector switch. Simply unsolder or clip it out. It would be good to remember this technique when adding crystals to the other positions. Often you can save additional crystal expense and redundancy by doing so. The IC-6F is supplied with crystals for channel 1 position only, usually at 52.525 MHz transmit and receive (simplex).

G. Crystals:

The erroneous thought that "crystals are crystals" or that one manufacturer has a bigger name and more expensive crystal so it must be better, will and does lead to some frustration in selecting additional crystals for your transceiver. Assuming accuracy, the most important other consideration has to be crystal activity. The amount of drive an oscillator can conjure up is dependent on crystal activity, and thus the overall performance of your transceiver is grossly affected. The crystals supplied are manufactured with a very high quality synthetic quartz which yields extremely high activity. If new crystals are added that have substantially less activity, the oscillators will not function with sufficient drive or fail to oscillate completely.

All domestic crystal manufacturers have been supplied with crystal data on your transceiver. We recommend, however, you order additional crystals directly from your dealer. He will have original replacement crystals on hand to meet your needs or can recommend a manufacturer who can supply you with proper types. You may also order directly from Varitronics.

If you find it necessary or expedient to order directly from a manufacturer, the following correlation data is provided. Remember to specify

high activity as prerequisite to your acceptance.

CRYSTAL DATA

Holder Type: HC-25/u
Calibration Tolerance: 0.0025%
Load Capacitance: 20 pf
Effective Resistance: 15 ohms or less
Transmit Crystals: IC-2F

Crystal Frequency
Desired Operating Frequency
8

Receive Crystals: IC-2F
Crystal Frequency
Desired Operating Frequency — 10.7 MHz
3

Transmit Crystals: IC-6F
Crystal Frequency
Desired Operating Frequency
8

Receive Crystals: IC-6F
Crystal Frequency
Desired Operating Frequency — 10.7 mhz

Trimmers have been placed on the crystal board to assist you in "tweaking" new crystals on frequency. Consult the trimmer location chart (Fig. 9) for their positions.

The amount of frequency spread between any two receiving or any two transmitting frequencies should not exceed 1 MHz. Since the receiver and transmitter are independent of each other, you may have any practical amount of frequency separation you wish here. Only two or more widely spaced frequencies for the receiver alone or for the transmitter alone need be considered under the 1 MHz limitation. Example: transmit 146.34 MHz, receive 145.60 MHz is satisfactory. Transmit 146.34 MHz and transmit 147.94 MHz is not possible. Receive 146.94 MHz and receive 144.94 is not possible.

Consult the CRYSTAL FREQUENCY ADJUSTMENT VIII-C, section of this manual for further information.

H. External Speaker:

An external speaker jack and plug is supplied with your unit in the event another speaker is desirable. The external speaker impedance should be 8 ohms. The use of the external speaker jack will disable the internal speaker. An 8 ohm headset can be utilized as well.

V CONTROL FUNCTIONS

A. Front Controls and Jacks:

1. On-Off Switch: Opens or closes the 12 VDC source voltage to the transceiver.

2. Volume Control: Controls audio output level of the receiver.

3. Squelch Control: Controls the squelch threshold point of the receiver.

4. Mike Jack: Accepts 3 prong mike plug supplied on microphone.

5. S-RF Meter: Reads "s" signal strength

in receive mode and relative RF output in transmit mode. The meter face is illuminated with a white lamp when transceiver is switched on and in receive condition. In transmit condition a red lamp lights also.

B. Rear Jacks:

1. RF Output Jack: Accepts standard PL-259 coaxial connector. Note: Some transceivers may come with a metric threaded connector. If this is the case, a mating metric PL-259 is supplied also. Most domestic PL-259 connectors will mate satisfactorily if care is taken to seat them properly. If you have difficulty, try a different make of PL-259.

2. Accessory Plug and Jack: This plug and jack permit direct connection to the receiver discriminator circuit. A "center 0" meter, +50 μ a may be connected to monitor incoming signal

frequency. See schematic drawing for wiring details and discussion of meter function in the IC-3P AC power supply instructions.

3. External Speaker Jack: This jack mates with the plug supplied for external 8 ohm speaker or headset use. The use of this jack mutes the internal speaker.

4. Fuse Holder: A regular 2 ampere fuse is used. In the event replacement becomes necessary, DO NOT REPLACE WITH SLOW BLOW TYPE.

5. Power Receptacle: Mates with DC cord plug or power cord of IC-3P AC power supply.

6. Identification Plate: States model, serial number and date of manufacture. Note: It would be well to make a separate record of the serial number of your unit for insurance purposes.

VI OPERATION

A. Operation of your transceiver is simplicity itself. No tuning is required. In the following instructions, it is presumed the DC source and a well-matched antenna are connected.

1. Receive Mode: First select the channel you wish to operate on and set channel selector accordingly. Turn ON-OFF switch to "ON." Turn the Squelch Control to its maximum counterclockwise position. Adjust volume control to comfortable listening level of noise when no signal is present. Carefully advance the Squelch Control till the noise just disappears. This is the proper squelch threshold setting. Your transceiver will now remain silent until an incoming signal is present.

2. Transmit Mode: In order to transmit, you have only to push the microphone switch and,

holding the microphone two inches from your mouth, speak in a normal tone. Release of the mike switch will return the unit electronically to receive mode. A red light will show in the "S"-meter window in the transmit mode:

3. Repeater Operation: When using your transceiver in Repeater System applications a "squelch tail" will be heard immediately following release of the microphone button in most cases. This "squelch tail" presents a quick check as to transmitter and receiver operation. For additional information on Amateur Repeater Systems, refer to the various amateur radio publications and the Radio Amateur's F-M Repeater Handbook, Ken W. Sessions, Jr., K6MVH published by Editors and Engineers, New Augusta, Indiana.

VII THEORY OF OPERATION

Inasmuch as your transceiver incorporates several electronic functions which interface with each other, either continually or intermittantly, we will treat the Operation Theory in five different sections for clarity and ease of understanding. It is recommended you follow the block diagram and schematic drawing carefully during the following explanations. If during the explanation a circuit appears to have been overlooked, disregard it. Its function will be discussed in one of the other sections.

A. The Receiver - Transistors 1 through 14

A signal in the VHF range reaches the receiver antenna coil RT1 via J1, low pass filter FL3 and RF switching networks. RT1 may be found in the upper left hand corner of the schematic drawing. The LC characteristic of RT1 selects the desired portion of the VHF signal

and couples it to TR1, the RF amplifier. A Field Effect Transistor was chosen for TR1 for its high resistance to overload (cross modulation) and low noise character. The amplified signal is then passed through a High-Q Filter comprised of RT2, RT3, RT4, RT5, and RL1 to the base of TR2, the first mixer. Simultaneously, a signal generated by the first crystal oscillator is injected at the first mixer, which is 10.7 MHz below the original input signal. The first IF of 10.7 MHz plus intelligence is then selected at the output of the first mixer by IFT1 and passed through two ceramic 10.7 MHz filters which operate back to back to produce good pass band shaping and image rejection. See Fig. 2. At the output of the second ceramic filter the 10.7 MHz signal plus intelligence is injected at the base of TR4, the second mixer. Simultaneously, a signal from TR5,

volt reference Zener diode also makes up a portion of this base circuit. In the receive condition, TR30 conducts normally and a regulated 9 VDC is available for the entire receiver with the exception of the audio stages. TR29, on the other hand, is a PNP type transistor and the potentials at the base and emitter are identical. Since no conduction is possible in this condition no voltage is present in the transmitter. When the microphone switch is depressed, placing the transmitter in the transmit mode, pin 2 is connected to pin 1 of J5. The base of TR30 is then grounded through D16 and TR30 ceases to conduct. Simultaneously, the base of TR29 is grounded through 500 ohms. This upsets the potential differences and TR29 conducts, supplying voltage to the entire transmitter chain. ZD2, another voltage reference Zener diode provides the regulation for the transmitter oscillator, modulator and buffer.

D. RF Switching

The RF switching, that is the actual antenna switching between receiver and transmitter, is accomplished with diodes D9, D10, and inductors TL4 and RT8. These components may be found at the bottom right hand of your schematic drawing. Diodes D9 and D10 are of the high frequency switching variety. Their internal resistance is variable, by the application of DC, from approximately 1 ohm up to 7000 ohms or more. In the transmit mode, DC is applied to D9 via a 500 ohm resistor and TL4. Concurrently current also flows through RT8 and D10. At this point the internal resistance of D9 and D10 is 1 ohm

or less. Thus the transmitted RF is allowed to pass through D9 and to the output jack J1 via the low pass filter FL3. Since RT8 and D10 represent a highly resistive path (an actual short circuit), no RF is thus permitted to pass to the receiver section. When the DC is removed the diodes again assume a very high internal resistance. An incoming signal is therefore diverted to the receiver through RT8 and past D10.

E. A.P.C. (Automatic Protection Circuit)

One shortcoming of solid state devices in RF applications is their unforgiving approach to a high VSWR, shorted output, etc. They simply self-destruct or vaporize almost instantaneously. Some protection to the user must be afforded to guard against accident. The APC in your transmitter is an ingenious approach toward that end. The APC is made up of TR27, diode D12 (these components may be found in the bottom right hand corner of your schematic), and TR28, DD3 and diode D19 located left center of your schematic near TR29 and TR30.

Diodes D11, D12, and their connecting copper tracts on the PC board are arranged much in the fashion of a diode type VSWR bridge. The side by side tract permits mutual RF coupling between the two. D11's polarity is such that it detects the "forward" RF power, rectifies it and via FVR4 places it across the meter for a relative output indication in the transmit mode. This function has nothing to do with the APC,

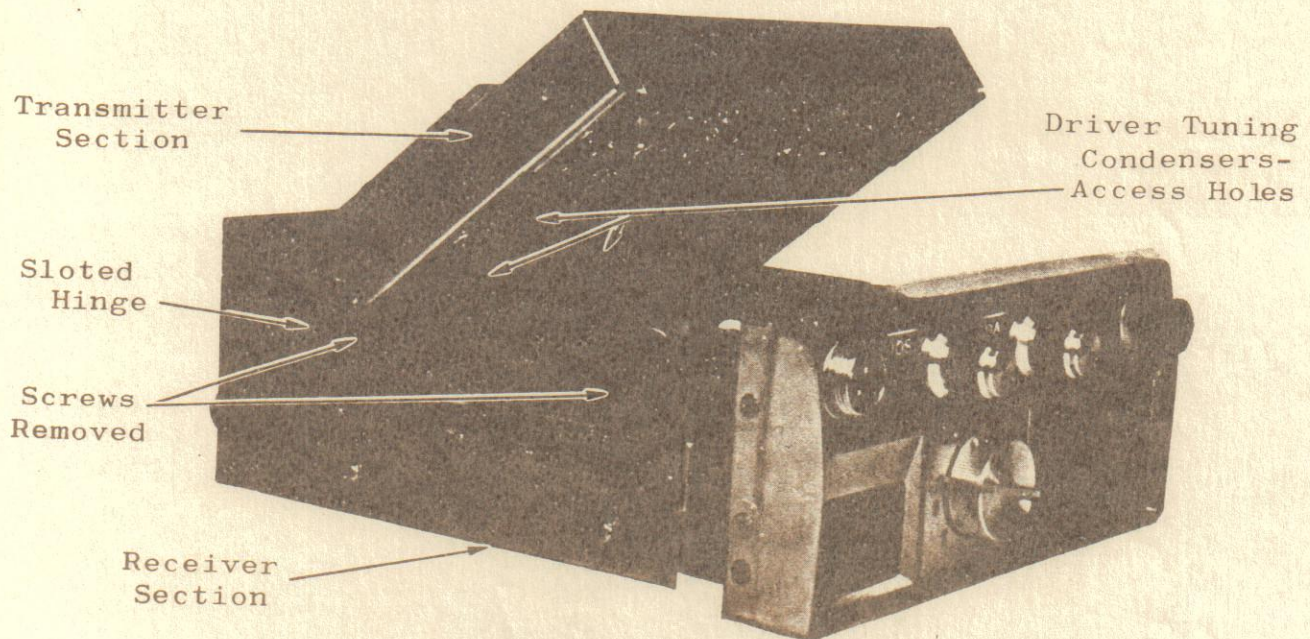
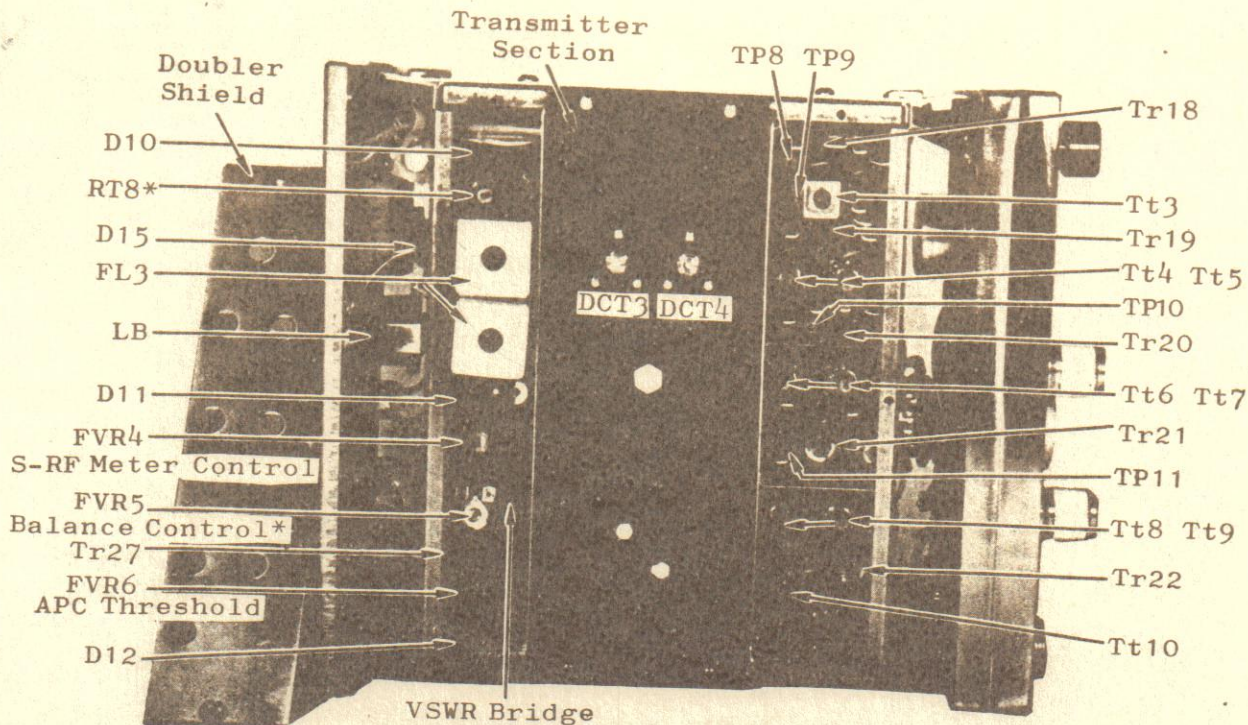

Fig. 5 OPENING THE INTERIOR CHASSIS

Note: Remove top two screws on each side to access transmitter final compartment



*FACTORY SET: DO NOT ADJUST

Fig. 6 BOTTOM INSIDE SECTION OF UNIT, WITH DOUBLER SHIELD REMOVED

of course. D12's polarity on the other hand is such as to monitor and detect any "reflected" power that might occur. When present, this detected power is rectified and placed at the base of TR27 via FVR6. This DC component is amplified by TR27 and injected at the base of TR28 via ZD3. Since ZD3 is oblivious to any amount of voltage less than a certain predetermined amount, it will not conduct. However, when that amount or more is present it conducts and places this voltage at the base of TR28. At this point TR28 breaks into conduction and adds to the unbalance potential at the base of TR29 the transmit voltage

switch. TR29's voltage output is instantly diminished or stopped altogether to TR22, the driver preamp, to TR23 and TR24, the driver and PA respectively. Collector current is concurrently diminished or stopped altogether in these stages, affording complete protection from damage. The severity of any mismatch in antenna, coaxial transmission line, connectors, etc., will determine if RF output will only be diminished or totally stopped. This is well to be remembered when tuning an antenna system or if a sudden dip in output is noted from your transceiver.

This completes the theory of operation.

VIII ADJUSTMENTS

It is altogether possible that the occasion may arise when you may wish to make one or all of the following adjustments. Doing so will not void your warranty. However, you are cautioned to follow the instructions carefully and then only if the proper tools and instruments are available.

WARNING: DO NOT ATTEMPT TO ALIGN OR ADJUST THIS EQUIPMENT WITHOUT ADEQUATE TEST EQUIPMENT AND A THOROUGH KNOWLEDGE OF STANDARD FM ALIGNMENT TECHNIQUES.

To do so is pure folly and could result in damage to the transceiver, poor performance, voiding of the warranty or all three.

A. Final P.A. OUTPUT Adjustment:

Tools required: in line wattmeter of the type mentioned before; a good 50 ohm, non-inductive load (low VSWR antenna or dummy load); an insulated tweaking tool; a 12 VDC regulated source.

Procedure: remove the four cabinet retain-
int screws and separate the transceiver from the two cabinet shells. Turn the transceiver upside down (crystal board side down). Affix dummy load or antenna, power source and microphone. Turn the unit on. You will note two slotted condenser shafts protruding through the back heat sink covering of the final PA compartment (see Fig. 6). Press the microphone button (modulation not necessary)

and note the output on the wattmeter. If it is lower than 10 watts, carefully adjust the final condensers with the insulated tool for maximum output on the wattmeter. Continue tuning alternate condensers until maximum output is obtained. This point will be between 10 and 12 watts. If you are unable to reach proper output and you are sure of the wattmeter's accuracy, it may be necessary to adjust the driver condensers. This is accomplished in the same manner as the final PA condensers. The driver condensers are accessible through chassis holes located on the bottom side of the transmitter chassis. Simply remove the four screws from the transmitter chassis (see Fig. 5) and swing chassis up on its hinges. Peak condensers through the shield for maximum output and then repeat final PA adjustment.

B. Transmitter RF Deviation Adjustment:

Tools required: same as above plus an accurate deviation meter.

Procedure: return chassis to upright position (crystal board up). Locate deviation control, FVR1, (see Fig. 7) on rear board. It may be upright or lying parallel to the board. Key the microphone and speak normally into it. A series of "fives" is a good test. While speaking into the microphone, note the deviation on the scope or meter of the deviation meter. By adjusting the deviation pot, you may vary the deviation from + 5 KHz (narrow band) to +15 KHz (wide band) to suit your own preference.

CAUTION!

The deviation pot FVR1 is of the subminiature variety and can be damaged easily. Treat it gently.

C. Crystal Frequency Adjustment:

Tools required: same as for Final PA Adjustment, plus a frequency counter.

Procedure: loosely couple the input of the frequency counter to the transceiver. Usually, a small loop placed on the top of the PA compartment will suffice. Place the channel selector switch in the channel position to be adjusted and key the mike switch. Making sure you have sufficient signal to the counter, adjust the crystal trimmer for correct frequency (see Fig. 9). For receiver frequency adjustment, couple the frequency counter to the receiver crystal oscillator coil. While injecting a signal of known accuracy, trim to frequency with the receiver crystal trimmer. This can be accomplished by ear on the air when a signal generator or counter is not available. Simply trim for maximum "S" meter reading on the incoming signal. It is presumed the incoming signal is of known accuracy, of course.

D. APC Adjustment:

Tools required: same as final PA adjustment.

Procedure: see Fig. 6 for the location

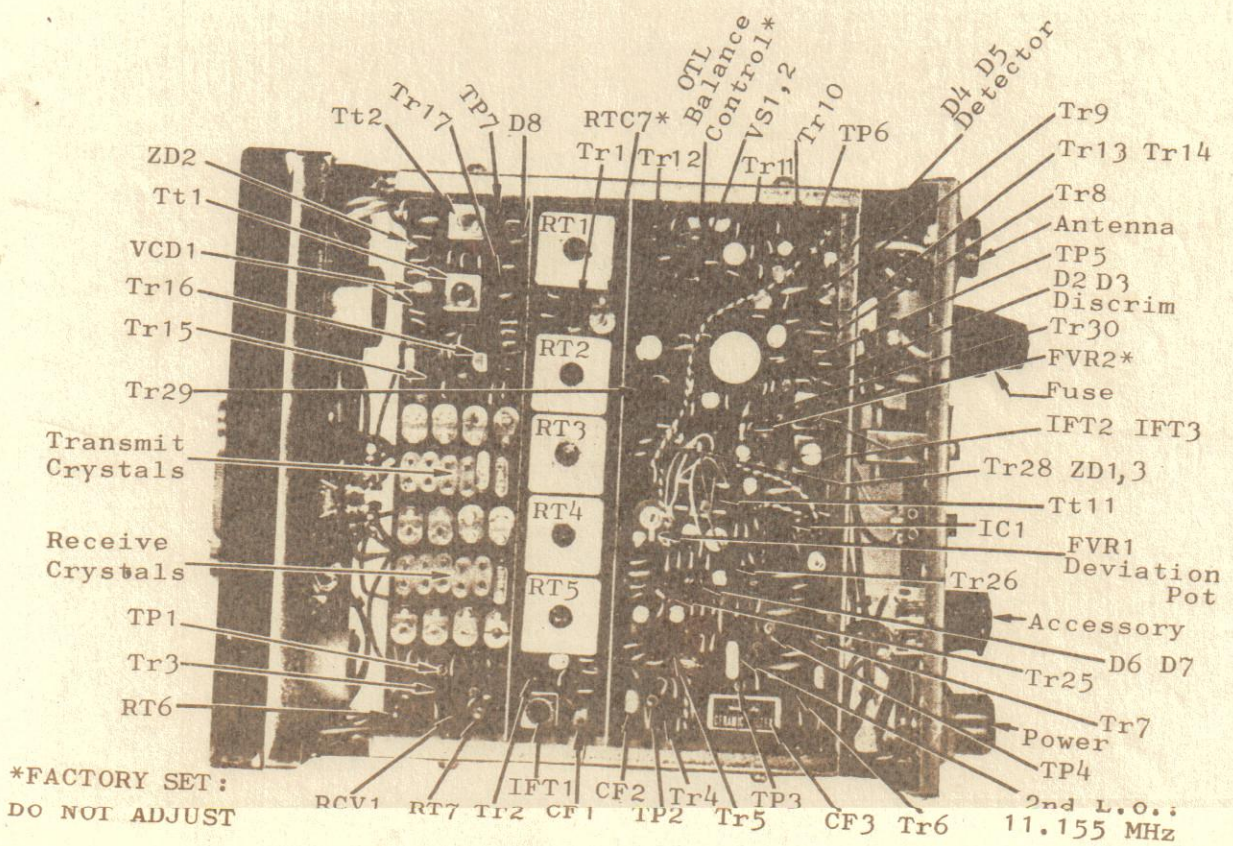

*FACTORY SET:
DO NOT ADJUST

Fig. 7 TOP INSIDE SECTION OF UNIT

TR21. The use of only three doubling circuits to reach the output frequency greatly minimizes the spurious response possibilities of such circuits. TR22 serves as another interstage buffer amplifier. Its output is coupled to the driver, TR23, via an adjustable series tuned network comprised of DTL1 and DTC1. The output of TR23 is then coupled to TR24, the PA. The now highly amplified signal is coupled to the remaining output circuitry, comprised of RF switching, low pass filter, and APC, via a series tuned resonant circuit comprised of tank coil DTL7 and condensers DTC4 and DTC3.

The IC-6F RF output circuit differs greatly from the IC-2F as illustrated in the schematic. Two output transistors, TR25 and TR26, are utilized instead of a driver and final arrangement of the IC-2F.

Output filter FL3 is a low pass, two section Pi, "m" derived type. In both the IC-2F and IC-6F this filter is designed for maximum spurious response rejection. Very high attenuation in the order of 60 db or more is normal.

Although not shown on the schematic drawing oscillators, multiplier circuits, RF circuits in both transmitter and receiver are carefully shielded from each other to prevent interaction. This shielding along with filters, proper grounding and short lead dress make your transceiver nearly void of spurious radiation.

C. Regulator and DC Switching
Voltage regulation and the DC switching or your transceiver centers around TR29, TR30, ZD1 and ZD2. These components may be found in the left center of your schematic. TR28's function in this configuration will be explained under APC.

In order that you may fully understand the DC system, let's begin at the power input plug, J2. The $\pm 12VDC$ is at pin 1 and the negative return at pin 3. Following the plus lead a 3 amp fuse is the first item. This is followed by diode D15. D15's polarity is such that accidental reverse polarity hookup of the transceiver will result in an instantaneous short circuit. This shorting will blow the fuse and the diode most likely, thus protecting the transceiver from severe damage. Following D15 is a LC filter comprised of an iron core inductor, LB, and a 470 ufd capacitor. This filter is designed to remove any alternator/generator "whine" component from the DC supply source. This filter is followed by the Power Switch and two indicator lights, "P" and "T". Note that "P" is provided with a ground and "T" is not. The "P" light therefore will light immediately upon the closing of the Power Switch. This serves as an indicator the unit is on and receiving voltage from the source. Light "T", which is red, is on only when grounded via mike jack J5 in the transmit condition. The plus 12 volts then appears at the base circuit of TR30 via mike jack J5 and diode D16. ZD1, a nine

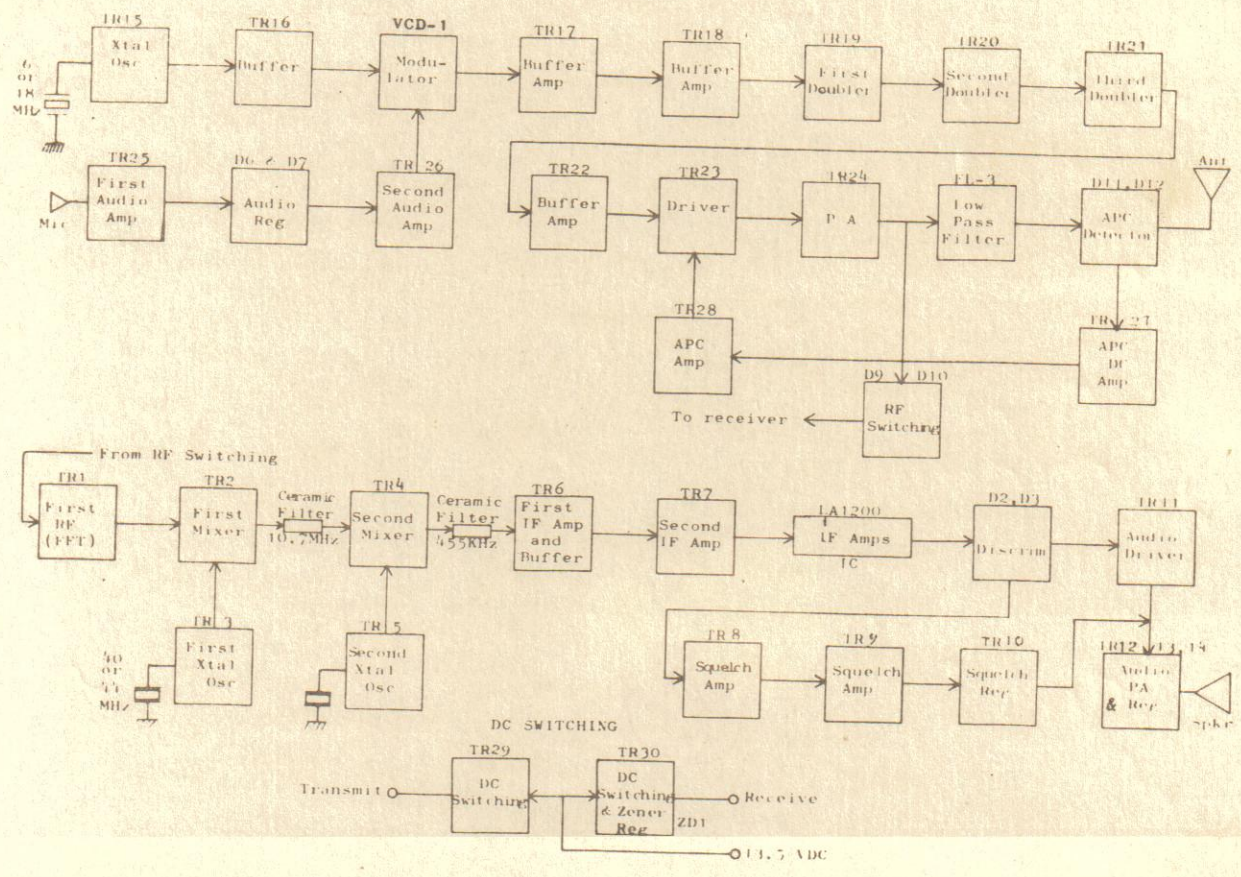

the 2nd crystal controlled local oscillator, is also injected to the base of TR4. At the output of TR4 the second conversion takes place and the 455 Kc component plus the intelligence is directly coupled to CF3, a 455 Kc ceramic filter. This filter is of such a design as to present excellent response while at the same time minimizing noise and ripple. See Fig. 3. The filtered 455 Kc signal plus intelligence is now coupled to TR6, a buffer amplifier, followed by TR7, an IF amplifier, and injected at pin 5 of IC1. From TR6 through IC1's output at pin 13, the signal has undergone over 100 db of amplification. Since so much gain is accomplished at this level, the necessity of additional RF amplification at the front end is eliminated. The now highly amplified IF plus intelligence is coupled to IFT2, 3 and associated network containing diodes D3 and D2. This configuration forms the Discriminator where the demodulation process extracts the usable intelligence which is then coupled to TR11, the audio driver via a 10 K ohm volume control. The amplified audio at the output of TR11 is then coupled to TR13 and TR14 which operate as a common emitter OTL audio amplifiers which drive the speaker directly or provide audio at J4 for an auxiliary speaker or headset. TR12, along with VS1, VS2 diodes and a 30 K ohm function as audio clipping and balance to produce clear, undistorted audio reproduction. The squelch circuit is made up of TR8, TR9, diodes D5 and D4 and TR10. In the absence of a signal, the noise component at the output of the discriminator is amplified by TR8 and TR9. Diodes D4 and D5 rectify this amplified component and couple it via the 10 K ohm squelch control to the DC amplifier TR10. TR10's output is coupled directly to the base circuit of TR11. When the squelch control is adjusted, the amount of DC required to cut off TR11 is found, thus establishing the squelch threshold. When a signal is incoming via the discriminator, this bias is overcome permitting the audio amplifier and driver to perform normally.

There are several items within the receiver circuitry we should like to point out. First, note that the first local crystal oscillator, TR3, has two outputs, A' and A''. A' is the IC-6F output. A'' is the IC-2F. The diode in the A'' portion of this circuit is used to create the necessary harmonic output for the two meter mixing process. Further note that the voltage

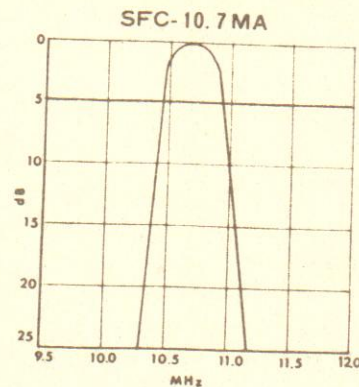
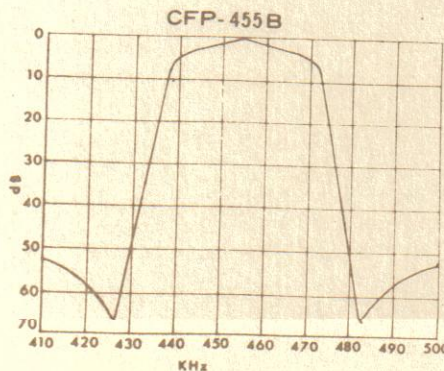

Fig. 2 10.7 MHz Filter Shaping

source for TR3 is acquired directly from TR30 the voltage regulator. Thus, voltage stability and frequency stability are insured at this stage.

Diode D14, which appears in the collector circuit of TR7 acts as the "S" meter DC rectifier. From this IF source, relative incoming signal strength is derived.

Discriminator current may be read at J3 and J2. Note that this is coupled from the discriminator via R8, a 20 K ohm resistor. By connecting a "center O" meter of 50 ua sensitivity to J3, incoming signal frequency can be measured. The matching AC power supply, the IC-3P, has this meter included in its cabinet and the power cord connection has the meter wiring also at J2. A thermistor, TH1, is utilized in the base circuit of TR8. This arrangement stabilizes the squelch settings. Thus, changes in temperature have little or no effect on squelch threshold.

Test points have been brought up from the receiver boards as well as for the transmitter. Voltage measurements at these points will be discussed later in this manual under "Maintenance-Trouble Shooting."

B. The Transmitter - Transistors TR15 Through TR26

TR15, which may be found far left center of your schematic, is a Clapp crystal oscillator running at 18 MHz in the case of the IC-2F and 6 MHz for the IC-6F. Its output is coupled to TR16, a buffer amplifier. At the output of TR16 the phase modulator configuration comprised of Tt1, VCD1, and Tt2 is found. An audio signal at the mike jack J5 is amplified by TR25. Diodes D6 and D7 at the output of this stage serve to establish the average modulation ratio at a desired level. The audio is then coupled to TR26 and the modulation transformer Tt11 at its output. Now impedance matched, the audio is coupled to the phase modulator circuit via deviation control FVR1. At this point the audio, plus RF generated at TR15 and amplified by TR16, are combined by Tt1, VCD1, and Tt2 by creating a phase shift in the RF components. The now phase modulated signal is amplified by buffer amplifiers TR17 and TR18. The output LC circuit Tt3 is so adjusted as to permit TR19 to double the frequency. And so it is through TR20 and

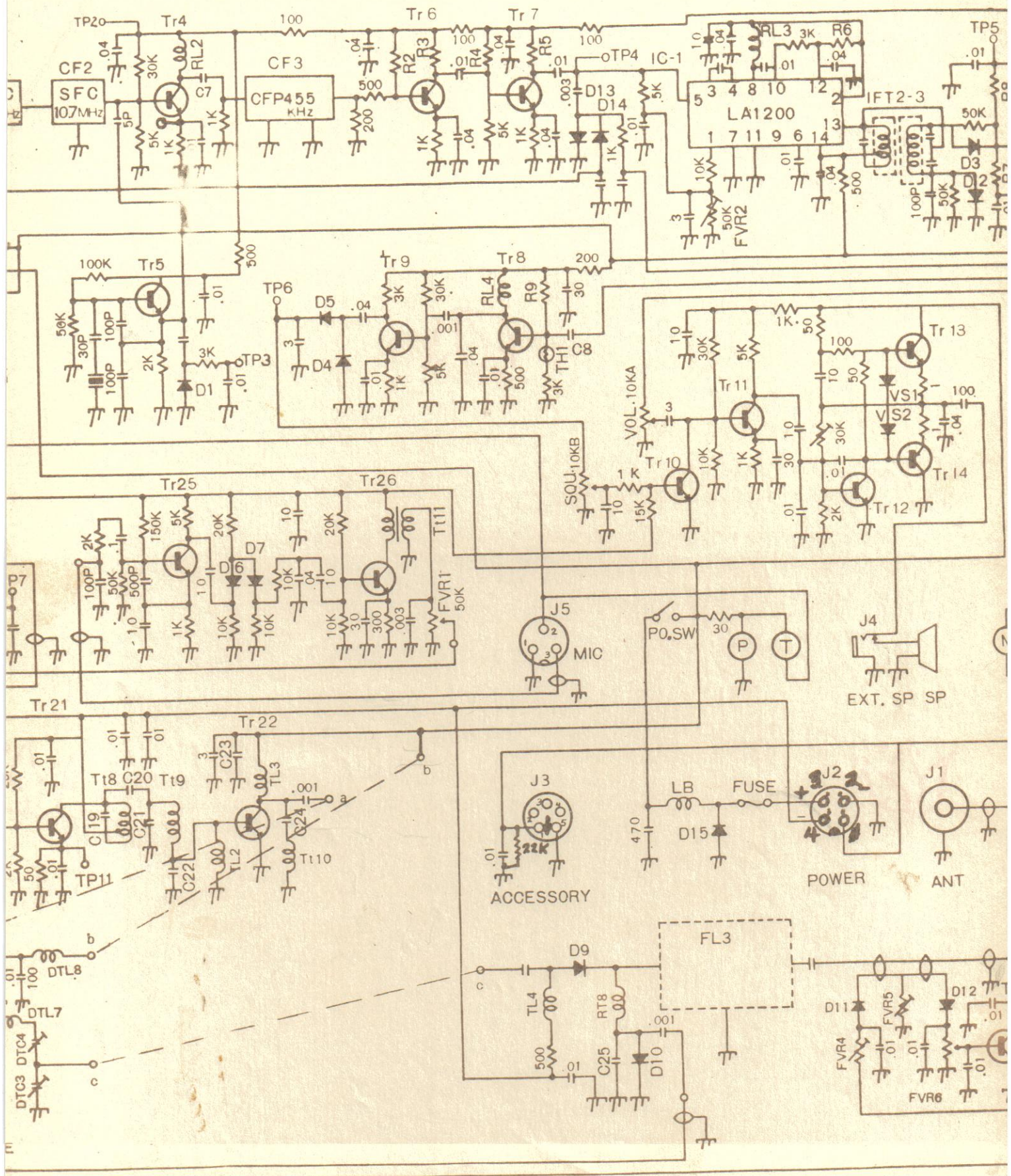

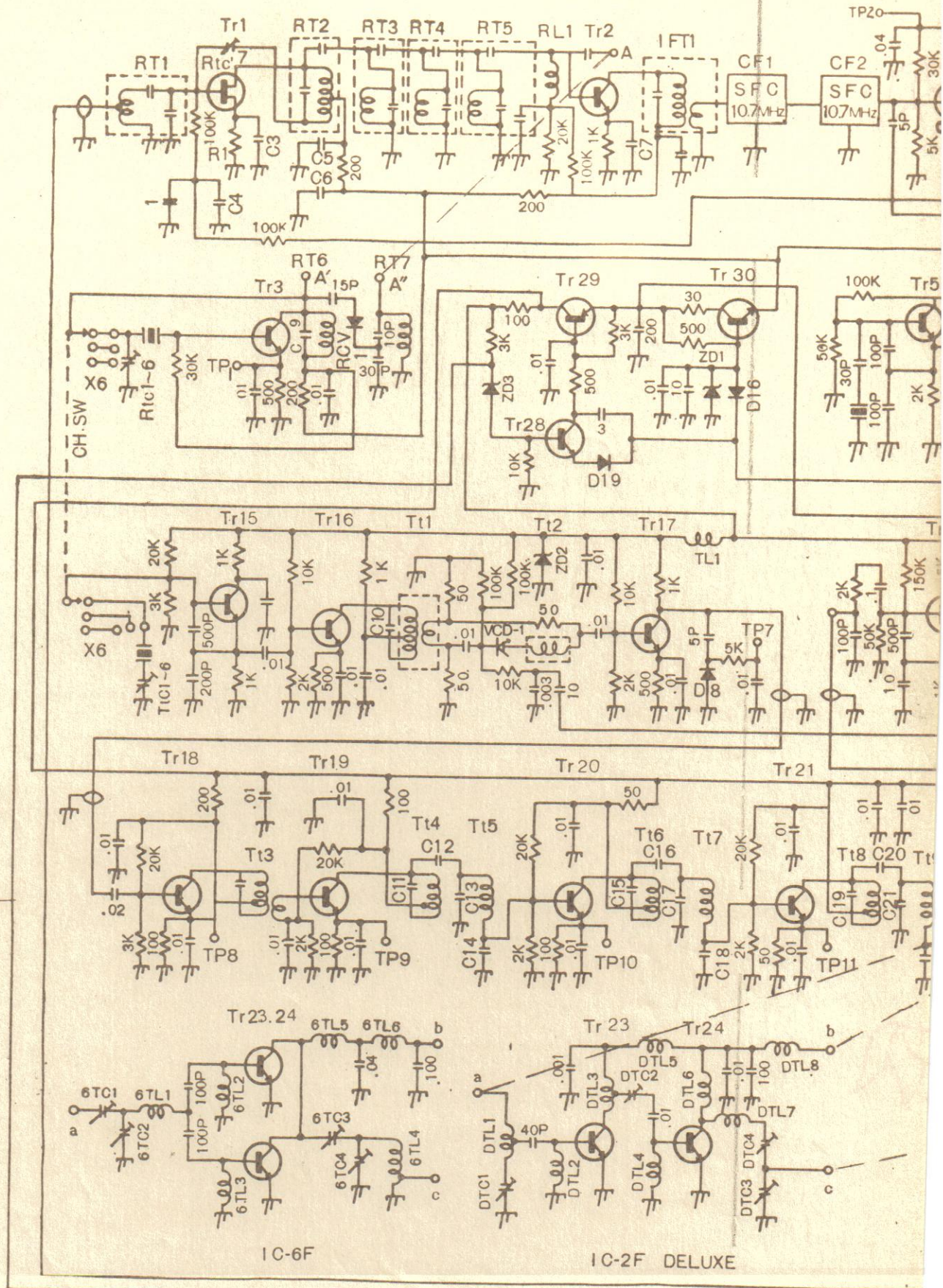

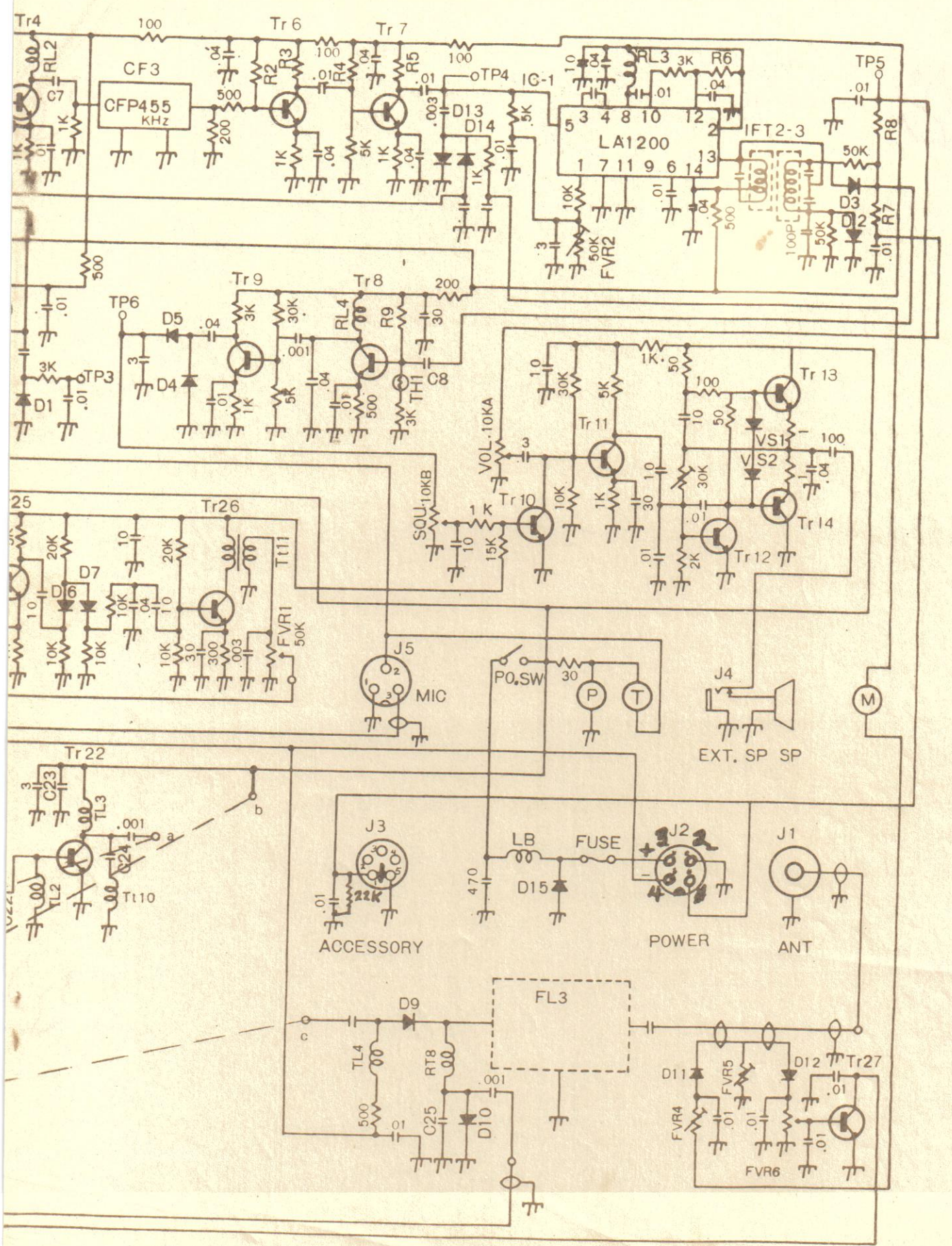

its manufacture and warranty service to insure it meets its specifications. Adjustments other than those outlined under the adjustment section of the manual should not be undertaken unless the owner is highly skilled in such techniques. The unit should be returned to us while in or out of warranty, instead.

Since component failure is the most common cause of difficulty, the following chart of test point voltages will be of assistance in locating the particular stage at fault. Armed with this information, the user can draw proper conclusions as to what remedial course he may wish to undertake, what component may be at fault and require replacement or a lead to a more serious problem. All measurements are made from chassis (black VTVM lead) to point under test (red VTVM lead).

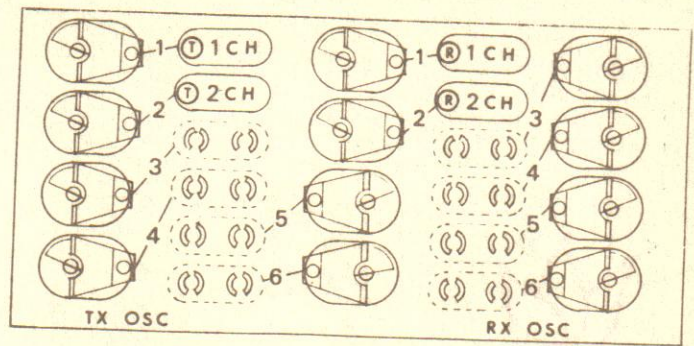

Fig. 9 Trimmer Location Chart

TEST POINT VOLTAGE CHART

See Fig. 6 and 7 for location

TEST POINT NUMBER	VOLTAGE	LOCATION OF TEST POINT	REMARKS
1	+3.3VDC	emmitter of receiver 1st local oscillator	+4VDC or more at this point indicates no activity
2	+ .98VDC	receiver 2nd mixer circuit	indicates mixer operating
3	+1.45VDC	2nd receiver local oscillator	oscillator operating and ok drive
4	with no signal input - .005VDC	receiver limiter circuit	injection of 10MV of signal-bring to -.19VDC
5	with signal input- 0 VDC	receiver discriminator	+or - VDC at this point discriminator misaligned
6	with no signal input- 2VDCnom	receiver noise amplifier	squelch circuit operation .1YV injection should=+.7VDC
7	+ .68VDC	transmitter modulator output	VDC at this point would indicate no RF drive
8	+ .7VDC	transmitter 1st multiplier	+ .55VDC or less indicates no drive
9	+1.2VDC	transmitter 2nd multiplier	+ .9VDC or less indicates no drive
10	+1.5VDC	transmitter 3rd multiplier	.5VDC or less would indicate no drive
11	+1.4VDC	transmitter multiplier buffer	.15VDC or less indicates no drive

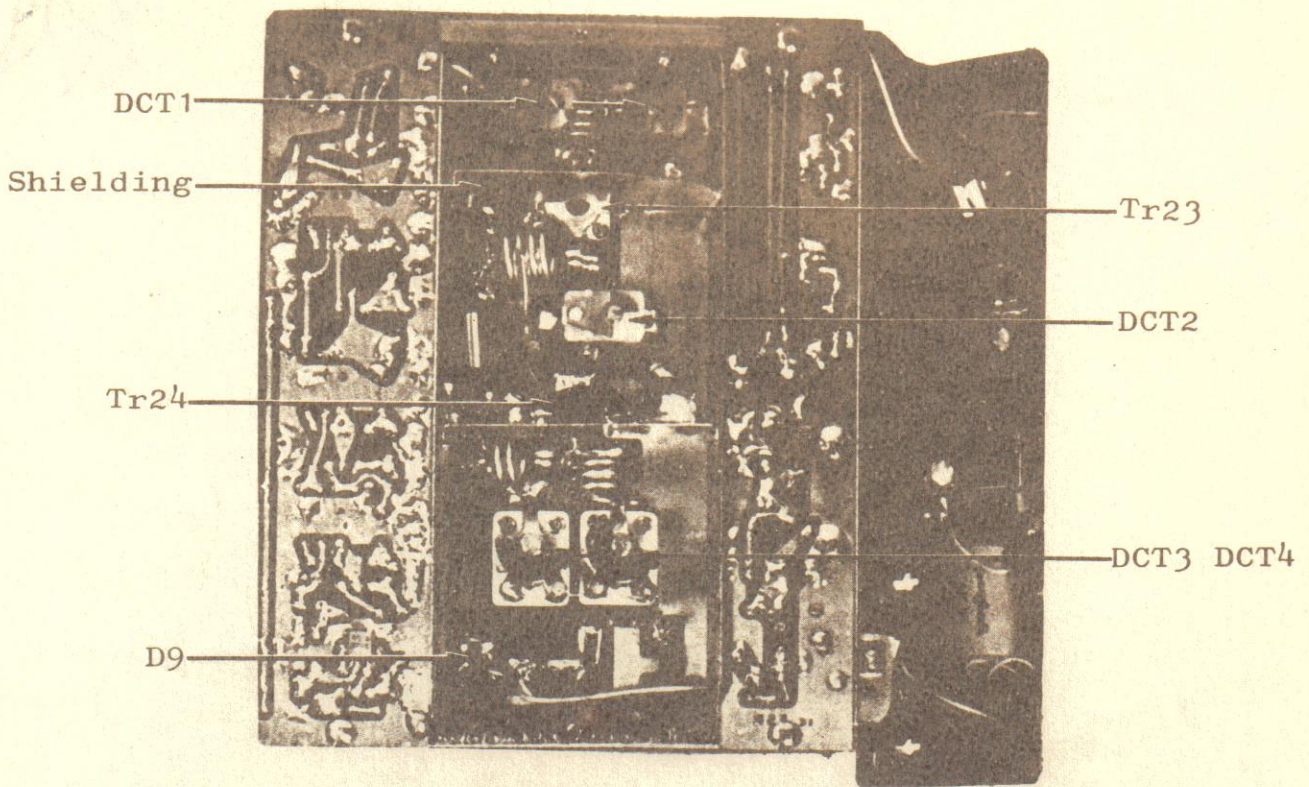

Fig. 8 TRANSMITTER SECTION FOLDED OUT, WITH SHIELD REMOVED
 Note: Remove section gently from slotted hinge on main chassis.

of the APC threshold control, FVR6. On some units, access to this control can be made through a small hole in the rear chassis. It is important that the dummy load being used in this adjustment be 50-52 Ω and non-inductive. Adjustments made on some other type will render the APC ineffective or useless. Proceed by depressing the mike button on and off several times, while making note of the output on the watt meter. Continue doing so while adjusting FVR6 slightly through its range. A point will be reached where the transmitter will not come on. Return the control the opposite direction until the transmitter does key on. Leave the control in this position and depress the mike button several

more times to make sure the transmitter keys and returns to receive properly. This is the proper threshold setting and will afford complete protection to the unit. As a final check, remove the dummy load and while watching the S-RF meter depress the mike button momentarily and release. The meter should not indicate RF. If it does, go back and complete the entire procedure again until this test is possible. Under no circumstances leave transmitter on without a load for more than just a momentary touch of the mike switch. If working correctly the meter needle will not move at all or only slightly and return to 0. This completes APC threshold adjustment.

IX MAINTENANCE - TROUBLE SHOOTING

Reasons for failure of your transceiver to operate can fall into four broad categories:

- (1) Manufacturing defect and component failure
- (2) Accidental mishap
- (3) Abuse
- (4) Incompetent misadjustment

Experience has taught us that numbers one and four respectively are by far the most responsible for failure in our equipment. For that reason, complete and detailed alignment procedures are not incorporated in this manual. The necessity arising to completely realign a unit is infinitely small. Almost without exception it is component

failure that causes the breakdown. To further defend this position, it is unlikely the average owner would have the instrumentation and facilities to accomplish a full re-alignment if it did become necessary. If he did have such facilities it is not too presumptuous to assume he would know how to use the instrumentation and be a fully qualified FM technician anyway. If this is the case, no formal alignment instructions would be necessary and techniques well known to him can and will suffice to align the unit. All of the foregoing by way of saying this... the IC-2F and 6F are complicated and, electronically speaking, delicate machine. Precision instrumentation and test jigs are employed in

For convenience in trouble shooting, the following chart has been prepared from our experience. It must be emphasized the probable causes listed are just that . . . probable not necessarily the only causes.

X AC POWER SUPPLIES TROUBLE SHOOTING CHART

A. General

Your transceiver will perform adequately on any 117 VAC/15 amp supply provided the following precautions are observed:

Complaint	Probable Cause
No transmit	APC shut down from high VSWR. Switching transistor TR 29 damaged from high voltage. Mike switch, cord or plug not making.
Low RF output	Poor load with poor match. Low DC supply voltage. PA improperly tuned. Driver improperly tuned. Final PA transistor TR 24 damaged.
Poor or low transmitted audio	Improper deviation setting. Defective microphone.
Unit transmits all the time	Switching transistor TR 29 damaged from high voltage.
Receiver audio very low or absent	TR 11, 12, 13 or 14 damaged from high voltage. J4 contact partially closed.
Receiver sensitivity low	Low activity crystals in use. Antenna problems.
Distorted receiver audio	Discriminator out of alignment.
No receiver operation	Switching transistor damaged from high voltage. Crystal defective. Improper squelch setting.

Varitronics maintains a very adequate supply of direct replacement parts and components for all of its products. These are available at our cost plus postage upon request from any equipment owner. Please supply unit serial number with all replacement parts orders.

2. Locate the two discriminator transformers IF-2 and IF-3 (See location photo Fig. 7).

X AC POWER SUPPLIES

A. General

Your transceiver will perform adequately on any 117 VAC/12 to 14 VDC 3 amp supply provided the following precautions are observed:

1. Adequate regulation of both current and voltage under load is present. Serious degradation of receiver and transmitter performance will be noted if this requirement is not met. Under some circumstances damage to the transceiver may also be expected, especially with excessive voltage.

2. Due care exercised in the mating process to insure proper polarity between the power supply and your transceiver.

B. The Matching IC-3P AC Power Supply

In addition to supplying a more than adequate regulated voltage current source, the matching IC-3P AC power supply has many operating conveniences as well. The unit is so constructed as to provide an operating stand for your transceiver. Mating hardware is provided with the IC-3P which consists of two metal ears and four machine screws. These ears are mounted on each side of the IC-3P with the machine screws in the pre-drilled and tapped holes. When your transceiver is placed on top of the IC-3P the holes in the top of the mounting ears will match with the transceiver's mounting bracket tapped holes. The insertion of the large knurled mounting knobs will produce a very sturdy joining of the two units. You need only insert the power plug coming from the IC-3P into the power jack J2, plug the AC power cord to a convenient receptacle, attach your antenna and you're in service.

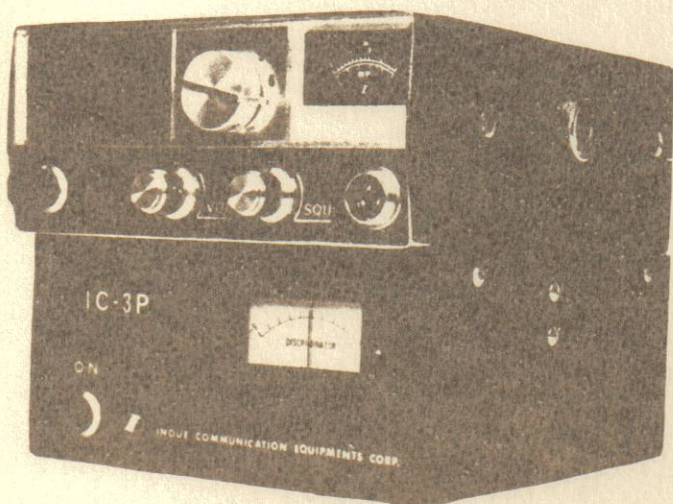

Fig. 10 Rear View IC2F/3P

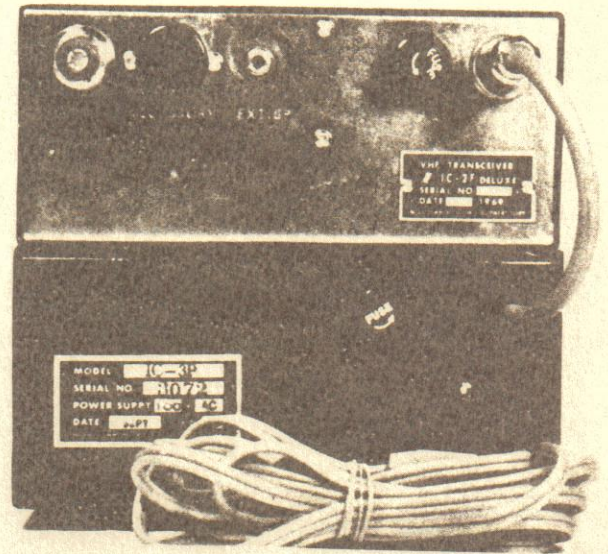

Fig. 11 IC2F With IC3P Power Supply

The discriminator meter in the IC-3P provides a convenient method to monitor frequency of incoming signals. It is of the "0" center type and the graduations to left or right of the center 0 are equal to +400 cycles each. Therefore, an "on frequency signal" will register a center zero reading whereas an off frequency one will register either + (high) or - (low) a determinable number of cycles. To properly insure the accuracy of the discriminator readings it may be necessary to align the meter with your transceiver's discriminator. The procedure for accomplishing this alignment follows and we ask that you kindly follow the instructions exactly and without alteration.

Discriminator Meter Alignment Procedure:

The order of accuracy of your discriminator meter is contingent on two criteria. First, that the receiver channel crystal is on exact frequency and second that the signal source used to align the discriminator is on exact frequency. You may reliably assume that the factory installed crystals provided with your transceiver are on frequency. This leaves the choice of the alignment source to you. If a frequency meter of high accuracy is available this would be the most desirable. If not, and your local repeater is of known frequency accuracy, you may use it instead. With the choice of this source made, proceed as follows:

1. Remove the top cabinet cover of your transceiver.
2. Locate the two discriminator transformers IF-2 and IF-3 (See location photo Fig. 7).
3. Place the transceiver on top of the IC-3P, connect power and AC source. If a frequency meter/RF generator is to be used, couple it very loosely to the transceiver and

adjust the generator to the proper channel input frequency. If the local repeater is to be used, connect your antenna to the transceiver.

4. With a modulated signal present, from the repeater or the proper frequency being injected from the generator, carefully note the discriminator meter reading. It may be off "0" center by several divisions.
5. With an insulated "tweaking tool" carefully adjust IFT2 and 3 until the discriminator meter needle is exactly on the zero line. This is a sensitive and critical adjustment and may require your making a second attempt to get the reading exact. In no event will it require you to move the adjusting screws of IFT2 and 3 but a very little.

Movement of less than a quarter turn is normal. This completes the alignment procedure.

In the squelched standby mode with no signal present it is normal for the meter to fluctuate off zero and at times show movement. This is due to random atmospheric or internal semiconductor noise and should be disregarded. You will note that the "S" meter will track with the discriminator meter in this case.

The AC to DC supply function of the IC-3P provides excellent voltage/current regulation. It is built with husky components throughout, and you may expect many years of trouble-free service. Since the design features of the IC-3P are quickly apparent from the following schematic, no formal theory explanation is made.

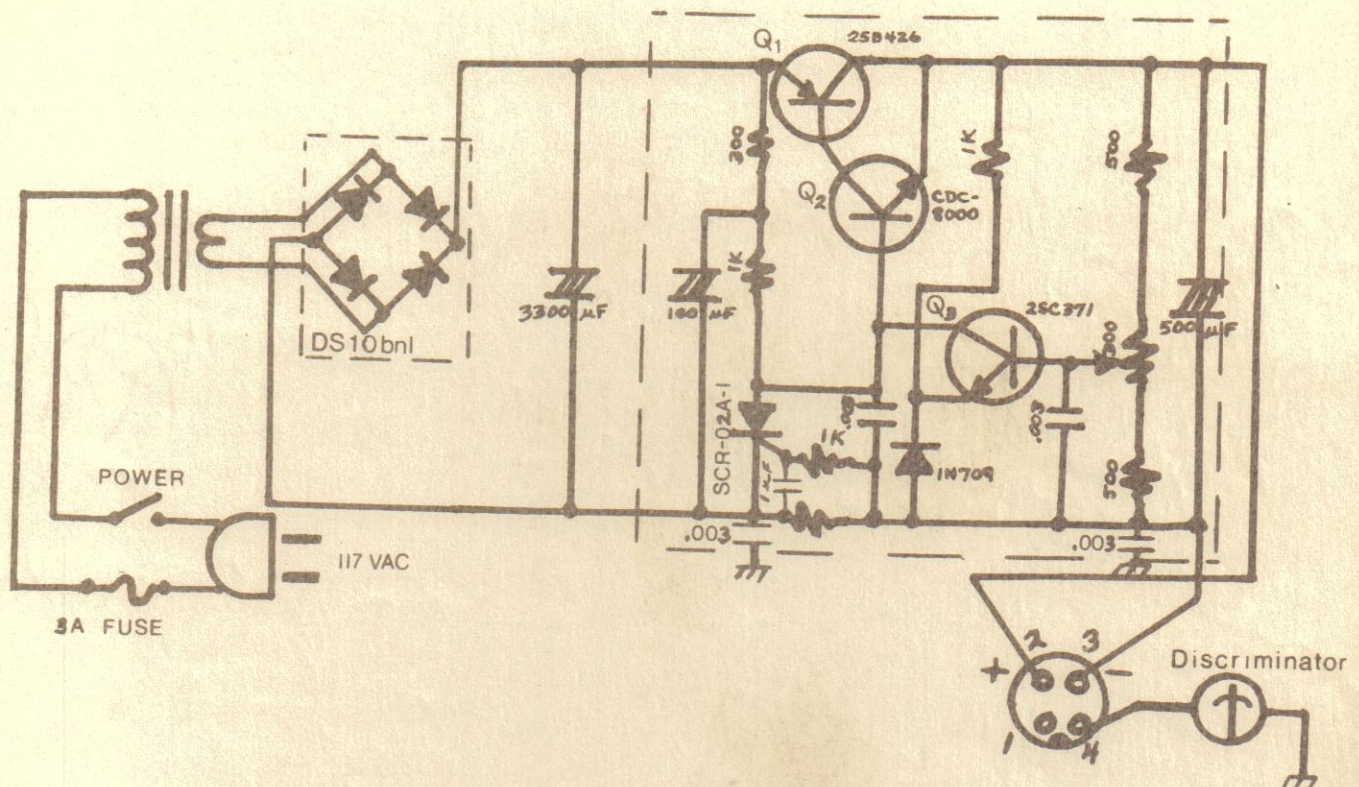

Fig. 11 IC-3P Schematic